

Secrets Of The Hajj

Secrets Of The Hajj



Husayn Mazaheri

**Translated by
Saleem Bhimji**

Al-Islam.org

Author(s):

[Husayn Mazaheri](#) [1]

Publisher(s):

[The Islamic Publishing House \(IPH\)](#) [2]

Secrets, subtle points, and attitudes with which each action of Hajj must be carried out, enabling the Hajj to become more than a physical journey; a journey of the inner soul towards self-purification and the Almighty.

[Get PDF](#) [3] [Get EPUB](#) [4] [Get MOBI](#) [5]

Translator(s):

[Saleem Bhimji](#) [6]

Topic Tags:

[Hajj](#) [7]

[Soul](#) [8]

[Self Development](#) [9]

Biography of the Author

The author of this work, *Secret of the Hajj*, is the grand Ayatullah al Hajj ash-Shaikh Husain Mazaheri. Born into a religious family in 1934 in the city of Isfahan, Iran, Ayatullah Mazaheri was a mere 15 years old when he began his Islamic studies in the Hawza 'Ilmiyyah of Isfahan. He completed his 'Arabic studies under the guidance of the late Hajj Agha Ahmad Muqaddas. His higher studies were conducted under the guidance of Ayatullah Khadimi, and Ayatullah Fayyad.

Four years later, he moved to Qum to continue his studies under the supervision of the late scholar to-Qum Hajj Shaikh 'Abd al-Jawad Jabal al-'Amuli, the late Marja' Ayatullah al-'Uzma al-Sayyid Shahab al-Din Mar'ashi Najafi, and the late Ayatullah Shaikh Murtada Haeri.

For more than eight years, he studied Dars-e-Kharij under Ayatullah al-'Uzma al-Hajj al-Sayyid Husain Burujerdi, and then ten years under Ayatullah al-'Uzma al-Hajj al-Sayyid Ruhullah Musawi Khumayni, and twelve years under Ayatullah al-'Uzma al-Hajj al-Sayyid Muhammad Muhaqqiq Damad. He also

studied the book *Al-Asfar* written by Mullah Sadra and *ash-Shifa* of Abu 'Ali Sind under the late 'Allamah al-Sayyid Muhammad Husain Taba'tabai – author of *Al-Mizan Fi Tafsir al-Qur'an*.

Since 1980, he has been teaching the higher classes of Fiqh and 'Usul, and he recently moved back to Isfahan to take over the responsibility of maintaining the Hawza 'Ihniyyah there.

This great teacher of Islamic Ethics has lectured extensively in Iran on ethics and spirituality. In addition to speaking and offering advice to the Muslims, many of his speeches have been compiled into books such as, *Jihad Ba Nafs (Struggle with the Soul – four volumes)*, *Upbringing of Children*, *Commentary on Dua al-Kumayl*, *Control of One's Sexual Urges*, *Ma'ad (Resurrection) in the Qur'an*, and countless others.

Introduction

What follows in this short book is a glance at the secrets of the *Hajj*, as expounded by the great scholar and teacher of Akhlaq (Islamic Etiquette) and 'Irf-an (Mysticism) Ayatullah al-Hajj ash-Shaikh Husain Mazaheri, presently living in Isfahan, Iran.

Hajj is one of the obligatory acts in Islam, which must be performed by each and every Muslim who is able to at least once in his or her lifetime if certain conditions are fulfilled. The books of ahadith are replete with wisdom from the Prophet of Islam and his twelve Successors (peace be upon all of them) concerning Hajj and the philosophical and mystical aspects behind the various acts performed. In the writing attributed to the sixth Imam, Ja'far ibn Muhammad al-Sadiq (peace be upon him) contained in *Lantern of the Path*¹, this noble personality explains Hajj in the following words:

“If you intend to go on pilgrimage, before resolving on it devote your heart to Allah, stripping it of every preoccupation and every barrier between you and Allah. Entrust all your affairs to your Creator and rely on Him in all your actions and moments of stillness. Surrender to His decree, decision and judgement. Abandon this world, repose, and all creation. Perform those duties which you are bound to fulfil for other people.

Do not rely on your provisions, the animal you will ride, your companions, your food, your youth nor your wealth, for fear that they will become your enemies and be harmful to you; in this way you will realize that there is no power, no strength, no might except by the guardianship of Allah and His granting of success.

Prepare for the pilgrimage as someone who does not hope to return. Keep good company, and be diligent in observing all your obligations to Allah and the Holy Prophet. Take care to show courtesy,

endurance, patience, thankfulness, compassion, and generosity – always putting others before yourself – even those who reject you. Then perform an ablution with the water of sincere repentance for wrong actions; and put on the robe of truthfulness, purity, humility and fear. By donning the garments of pilgrimage, withhold yourself from everything which hinders you from remembering Allah, or that may impede you from showing obedience to Him.

Fulfill His call with an answer whose meaning is clear, pure and sincere when you call on Him, holding on firmly to your belief in Him. Circumambulate with your heart along with the angels who circumambulate the Throne, just as you circumambulate with the Muslims who go around the Ka'bah. Hasten as you run in flight from your passion, freeing yourself of all your personal assumptions of strength and power. Leave your heedlessness and errors behind when you go out to Mina; do not desire what is unlawful for you and what you do not deserve.

Confess your errors at Arafat – set out your contract with Allah by His Oneness, draw near to Him and fear Him at Muzdalifah. Climb with your soul to the highest assembly when you climb the mountain of Arafat. Slit the throat of passion and greed in the sacrifice. Stone your appetites, baseness, vileness, and blameworthy actions when you stone the Pillar of Aqabah. Shave off your outward and inward faults when you shave your hair. Enter into the security of Allah, His protection, His veil,

His shelter and His watchfulness and abandon the pursuit of your desires by entering the Sacred Precinct. Visit the House, and walk around it to glorify the Master, His wisdom, His majesty and His power.

Embrace the Stone, being content with His decree and humble before His might. Leave everything that is other –than–Him in the valedictory circumambulating. Purify your soul and your innermost being for the meeting with Allah, on the day when you will meet Him when standing on al Safa¹.

Take on valour and courtesy from Allah by annihilating your attributes at al–Marwah. Be consistent in the conditions of your pilgrimage and fulfil the contract you have made with your Lord, by which you will have obliged yourself to Him on the Day of Judgement.

Know that Allah made the pilgrimage obligatory, and singled it out from all the acts of worship in respect of Himself when He said:

...وَلِلَّهِ عَلَى النَّاسِ حِجُّ الْبَيْتِ مَنِ اسْتَطَاعَ إِلَيْهِ سَبِيلًا

“Pilgrimage to the House is incumbent upon men for the sake of Allah, and [upon] everyone who is able to undertake the journey to it..” (3:97).

The Holy Prophet (‘s) established the organization of the rituals of pilgrimage, as preparation for and an indication of death, the grave, the resurrection and the Day of Judgement. In this lesson for mankind he

discriminates between those who will enter the Garden and those who will enter the Fire, through his demonstrating the pilgrimage rites from beginning to end, to those with intelligence and prudence.

It is hoped that this short booklet which elucidates on some of the subtle points of the Hajj will be of benefit to the brothers and sisters who are making this once in a lifetime journey to the holy cities of Makkah and Madinah. We pray that this small work is accepted by Allah, our Prophet Muhammad ('s), his close friend, brother, and immediate successor Amir al Mu'minin 'Ali ibn Abi Talib, and the 11 Imams from his family (as).

May this trip not only be a physical journey, but rather a journey of the inner soul towards self-purification and finally to the final abode – nearness to Allah (SWT) in every way.

May Allah hasten the return of our Mawla and Master, Sahib al-'Asr wa al Zaman (may our souls be sacrificed for the dirt under his feet).

Saleem Bhimji

Translator

[1.](#) This book has been translated into English by Fadlullah Haeri, and was originally published by Zahra Publications. The original title of the book in `Arabic is Misbah al-Shariyah wa Miftah al-Haqiqah.

The Hajj

The entire journey of Hajj is a spirituality excursion that covers three stages:

The First Stage: Cutting off affinity from all things with the exception of Allah in order to reach to Allah.

سير من الخلق إلى الحق

The Second Stage: Continuing towards Allah and strengthening the alliance (with Him), until one reaches to Allah and (the true) essence of worship.

سير من الحق إلى الحق

The Third Stage: Once a person has reached to the level of perfection and has arrived at the stage of (true) worship, he then returns (to the people) to guide the creations of Allah towards Him

The First Stage of the Hajj

In the first stage, above all other things, that which is the most important is repentance (*tawbah*) and to be vigilant. The meaning of repentance is to shun all devils and all forms of despotism, and turn back towards Allah. It means to disregard one's wishes, low desires and the lower *soul* (*al-Nafs al-Ammarah*) and proceed towards spirituality and the (higher) qualities (of a human being).

Completing all that was performed in the past such that there is no responsibility or obligation between Allah and His creations on the person's shoulders, the person leaves his city in such a state that not a single person is upset with him – except of course the Devil (*Shaitan*).

The meaning of being vigilant is that one focuses his attention on the grandeur and majesty of the House of Allah.

He focuses on the fact that it is the Creator and Maintainer of the Universe that has given him this opportunity (to perform the Hajj). He focuses on the fact that on this journey, he must not allow anyone or anything to aggravate him. He focuses on the fact that if he performs a Hajj that is accepted, then without doubt, he has reached to that level which mankind was created to reach to (the level of meeting Allah and the level of true worship). He focuses on the importance of performing all those things, which are obligatory to perform, such as the Salat, etc...

A woman performing the Hajj safeguards her modesty and her Islamic attire (*hijab*). She focuses on the importance of refraining from all sins, and she knows and understands that Allah does not accept the deeds of those who commit sins. The acceptance of all actions is connected to one's piety (*taqwa*).

Thus, Allah does not accept the Hajj from those people who commit sins:

إِنَّمَا يَتَقَبَّلُ اللَّهُ مِنَ الْمُتَّقِينَ

“Verily Allah only accepts from those who guard (against evil).” (5:27).

The person must keep in mind the importance of performing the recommended (*mustahab*) acts, most importantly of which is serving the creations of Allah, which is one of the ways that the obligatory (*wajib*) acts are accepted.

The person must keep in mind that especially during this journey, wherever he may be and in whatever

state he is, he is constantly in the presence of Allah, the Noble Prophet (s) and the Pure A'immah (as) (such as we are told in the Qur'an):

وَقُلْ اَعْمَلُوا فَسَيَرَى اللّٰهُ عَمَلَكُمْ وَرَسُولُهُ وَالْمُؤْمِنُونَ

“Say – Work! Allah will see your work and (so will) His Messenger and the believers..” (9: 105)

The person must keep in mind that using any forbidden (*haram*) wealth or property on this trip – rather in any act of worship, will not lead to anything except the accumulation of sins, transgression and misfortune in this world and in the next life.

After repentance and being vigilant, the person must also reach to a stage of emptiness and annihilation, such that if he cannot reach to the level where he is able to remove all the detestable characteristics such as *jealousy, miserliness, pride, greatness, worship of the world, etc...* then he should at least try to acquire the praiseworthy characteristics such as *mercy, generosity, humility, asceticism, and freeing the soul from all that it is attached to* within himself.

A person should try to at least control those detestable attributes that he possesses and not allow them to take power over him.

Similarly, one must try to allow justice, equity and the fear of Allah to rule over himself such that unknowingly and on its own, the soul gains control in a way that all the obligatory (*wajib*) actions are performed and all sins are refrained from. This should be accomplished at least to the extent that these (positive traits) take control over one's *al-Nafs al-Ammarah* and over one's own wishes and desires, and do not drag the person towards sin.

Once this has been accomplished, then one, through the pleasures of the religion (Salat, fasting, recitation of Qur'an, supplication, humility and humbleness while in the presence of Allah, pleasing the creations of Allah, etc...) and through seeking help by way of *Tawassul* to the Ahl al-Bayt (as) (it is better to go to Madinah after performing the Hajj, if one is able to), especially seeking help from *Imam Wali al-Asr* (may Allah hasten his noble return and may my soul and the souls of all of those of the universe be sacrificed for the dirt under his feet) and by the continuous recitation of *Ziyarat Jami'ah al-Kabirah* which is one of the best forms of *Tawassul* to the 12th Imam, one will reach to the level of glory and praise – meaning that our soul will become illuminated by the light (*Nur*) of Allah.

وَجَعَلْنَا لَهُ نُورًا يَمْشِي بِهِ فِي النَّاسِ

“And we placed for him, a light (Nur) by which he walks amongst the people..” (6: 122).

In this blessed journey, while in the security of the Truth, one should be able to reach to a level of true

servitude, where one can distinguish between good and bad, friend and enemy, and what Allah (swt) wants, from what one's own evil soul wants...

إِنْ تَتَّقُوا اللَّهَ يَجْعَلْ لَكُمْ فُرْقَانًا

“If you are careful of (your duty to) Allah, then He will grant you a distinction.” (8:29).

What is more important than which has been mentioned is at this stage, one must attain sincerity (*khulus*). This means that in one's heart and thoughts during this journey, nothing should remain except Allah and the performance of the Hajj exactly as the way Prophet Ibrahim (as) performed it.

وَجَّهْتُ وَجْهِيَ لِلَّذِي فَطَرَ السَّمَوَاتِ وَالْأَرْضَ حَنِيفًا وَمَا أَنَا مِنَ الْمُشْرِكِينَ

“Surely I have turned myself, being upright, wholly to Him Who originated the heavens and the earth, and I am not of the polytheists.” (6:79).

The person should not perform Hajj simply for people to congratulate him; or, may Allah protect us, to make other people work hard and go through troubles, meaning his Hajj is not simply to use other people. In fact, his Hajj should not even be for Allah to bestow upon him, both in this world and in the next, blessings and bounties. Rather, all of his attention and focus on this journey must be for Allah, the goal of reaching to Him and to the true worship, such that no one else or anything will be in his sight except the pleasure of Allah.

وَمَا لِأَحَدٍ عِنْدَهُ مِنْ نِعْمَةٍ تُجْزَى

“And no one has with him any blessing for which he should be rewarded,” (92: 19).

إِلَّا ابْتِغَاءَ وَجْهِ رَبِّهِ الْأَعْلَى

“except the seeking of the pleasure of his Lord, the Most High.” (92:20).

In summary, at this stage, one's intention must be sincere and there must not be anything of the worldly pleasure, in fact not even the pleasures of the next life should be in his sight. Just as the Qur'an mentions, the best *colour* is the *colour* of Allah

صِبْغَةَ اللَّهِ وَمَنْ أَحْسَنُ مِنَ اللَّهِ صِبْغَةً

“(Receive) the colour of Allah, and who is better than Allah in colouring?” (2: 138).

The worst of colours is the colour of conceit, and it is clear that if Allah forbid, through one's actions, speech, or if in one's heart or soul this trait is already there, then he has reached to the stage of disbelief (*kufr*):

فَوَيْلٌ لِلْمُصَلِّينَ

“So woe to the praying ones,” (107:4).

الَّذِينَ هُمْ عَنْ صَلَاتِهِمْ سَاهُونَ

“those who are unmindful of their prayers,” (107:5).

الَّذِينَ هُمْ يُرَاءُونَ

“Who do (good) to be seen,” (107:6).

وَيَمْنَعُونَ الْمَاعُونَ

“And withhold the necessities of life.” (107:7).

The Second Stage of the Hajj

In this level, the first action consists of wearing the *Ihram* at the *Miqat* (the station where the *Ihram* must be worn).

The *Ihram* of the Hajj is similar to the *Takbiratul Ihram* for *Salat*, such that when a person says the *Takbiratul Ihram* to start the *Salat*, one must leave behind all other things and focus one's entire attention on Allah. From the beginning of the *Salat* until its completion, nothing else must distract the person.

Such is the *Ihram* for Hajj – meaning that once it is worn, the person must leave aside all things related to the world. In its place, one must turn towards Allah and (that which is) His pleasure. At the time of donning the *Ihram*, one must fulfill the commandments of Allah.

One should remember the time of death and the wearing of the burial shroud (*kafan*), being placed in the grave, and the fact that one day, in this same attire, one will rise up to meet Allah.

At the time of saying the *talbiyyah* (sentences said after the wearing of the Ihram and making of the intention), one must pay attention to the fact that Allah has invited him/her. By saying this phrase (*talbiyyah*), one is in fact replying to Allah's call, and with an inner excitement, and while wavering between the two states of *fear* and *hope*, cries out, *Labbaik (here I am)!*

In the narrations, we read that at the time of reciting the *talbiyyah*, the Ahl al-Bayt (as) faced such an inner turbulence, trembling body, and change in colour of their skin, such that they did not have the power or ability to read the *talbiyyah!*

In fact in some instances, they would fall into a state of almost passing out and when asked why they were not reciting the *talbiyyah* while in this state, they would reply that we are afraid that the reply (from Allah) may come that:

لا لبيك ولا سعديك

“You are not accepted and you are not welcome. “

Second Action: The *Tawaf* is the second act. The Tawaf resembles the continuous act of the Angels circumambulating the Throne of Allah.

وَتَرَى الْمَلَائِكَةَ حَافِينَ مِنْ حَوْلِ الْعَرْشِ يُسَبِّحُونَ بِحَمْدِ رَبِّهِمْ

“And you shall see the Angels going round about the Throne glorifying the praise of their Lord.” (39:75).

Just as the Tawaf of the Angels around the blessed Throne of Allah is a sign of their love for Him, the Tawaf of the servants of Allah around the House of Allah as well is a sign of their love for Him.

By him performing the Tawaf, he is in fact proclaiming that his self, his wealth, his wife and children and whatever else he has in this world are all sacrificed for Allah (swt) and that he is ready to give everything he has in the way of Allah and only for His pleasure.

وَمِنَ النَّاسِ مَنْ يَشْرِي نَفْسَهُ ابْتِغَاءَ مَرْضَاةِ اللَّهِ

“And from the people is he who sells his soul seeking the pleasure of Allah.” (2:207).

By the repetition of the Tawaf and arriving to the state of complete submission and servitude, the veils

(between the servant and Allah) are one by one, torn away.

The veils of self-conceit and selfishness, pride and anger, lust and greed, jealousy and miserliness are removed; and in their place are embellished the covering of humbleness and indigence in the presence of The Truth, humility and forbearance in the presence of The Creator, and asceticism, generosity and contentment in the presence of the world (the level of emptiness and annihilation).

Only in this state, will the light (*Nur*) of Allah enter into the hearts (the level of glorification) and the person will experience the path towards peace and tranquility – one after the other.

All forms of evil and darkness (these are negative attributes such as the darkness of the evil soul, the following or obeying of all despots from amongst the human and jinn, the darkness of one's own wishes and desires, the darkness of grief, anger and anxiety) will be covered with the pure light (*Nur*) and a special recognition by Allah.

Willingly or unwillingly, one will reach to the level of closeness with Allah and of complete annihilation in Him – it is at this point that one has reached to the Straight Path (*Sirat al-Mustaqim*).

يَا أَهْلَ الْكِتَابِ قَدْ جَاءَكُمْ رَسُولُنَا يُبَيِّنُ لَكُمْ كَثِيرًا مِمَّا كُنْتُمْ تُخْفُونَ مِنَ الْكِتَابِ وَيَعْفُو عَنْ كَثِيرٍ ۚ قَدْ جَاءَكُمْ مِنَ اللَّهِ نُورٌ وَكِتَابٌ مُبِينٌ

“Indeed Our Messenger has come to you making clear to you much of what you concealed of the Book and passing over much; indeed, there has come to you light and a clear Book from Allah.” (5: 15).

يَهْدِي بِهِ اللَّهُ مَنِ اتَّبَعَ رِضْوَانَهُ سُبُلَ السَّلَامِ وَيُخْرِجُهُم مِّنَ الظُّلُمَاتِ إِلَى النُّورِ بِإِذْنِهِ وَيَهْدِيهِمْ إِلَى صِرَاطٍ مُسْتَقِيمٍ

With it Allah guides him who follows His pleasure into the ways of safety, and brings them out of utter darkness into the light by His will and guides them to the Right Path” (5: 16).

Third Action: The third act is the *Salat* of *Tawaf*. The person who has just performed the *Tawaf* – a performance that has raised one to the level of complete servitude, must perform a prayer of thanks.

Since one has reached to the level of slavery, the ascension (*me'raj*) has become obligatory on him, and the ascension of a believer is the *Salat*.

The *Salat* is comparable to a conversation between the servant and Allah (swt). The recitation of *Surah al-Fatiha* and the other *Surah* are in actuality, a mode of speaking with Allah through the words of the Creator to the Creator. All that which is read in the *Salat* including the various remembrances (*adhkar*) and glorification (*tasbihat*) is actually the servant speaking to Allah.

Since Tawassul and asking for help from the Ahl al-Bayt (as) in every one of our actions is necessary, thus, when the *tashahhud* and *salam* are read, it is actually a discussion going on between the servant and the Ahl al-Bayt (as). This too is actually another form of *Tawassul* between the servant and Allah (swt).

Therefore, the Salat is the best thing for a servant and is the action which brings about the most pleasure. In Islam, it has been mentioned that after cognition (*ma'rifah*) of Allah, the Salat is the best act:

أفضل الأعمال بعض المعرفة الصلاة

“The best of actions after cognition (ma'rifah) (of Allah) is the Salat.”

Fourth Action: The fourth act is *Sa'i* between the mountains of *al-Safa* and *al-Marwah*. The *Sa'i* between these two mountains is a re-creation of the beautiful historical event which was performed by one of the best creations of Allah after the Ahl al-Bayt, who, The Maintainer of the Universe has mentioned and acknowledged (that sincere action of this servant) in the Qur'an:

وَاتَّخَذَ اللَّهُ إِبْرَاهِيمَ خَلِيلًا

“And Allah took Ibrahim as a friend.” (4: 125).

It was truly a beautiful event in which a man submitted his complete entity to the Maintainer of the Universe and which He Himself personally endorsed:

إِذْ قَالَ لَهُ رَبُّهُ أَسْلِمِ قَالَ أَسْلَمْتُ لِرَبِّ الْعَالَمِينَ

“And when his Lord said to him, ‘Submit!’ He said, I have submitted to the Lord of all the Worlds.” (2: 131).

It was a magnificent event in which a man – only for the pleasure of Allah – constructed the House of Allah (swt) a place where people would inhabit. He then left his only son whom Allah granted to him when he was in old age, along with the mother of this child with the words of Allah (swt): ‘For you Allah and with hope in You, I am leaving my wife and my child and departing in a deserted area without water, food or any guardian!’

رَبَّنَا إِنِّي أَسْكَنْتُ مِنْ ذُرِّيَّتِي بِوَادٍ غَيْرِ ذِي زَرْعٍ

“O' our Lord! Surely I have settled a part of my offspring in a valley unproductive of fruit.” (14:37).

The Sa'i between the two mountains of al-Safa' and al-Marwah bring to mind the beautiful event in which a woman all alone – without water, food or protection – for the pleasure of Allah, was left in the valley and went on a desperate search to secure water for her only child. In a state of inner confusion, she ran from al-Safa to al-Marwah and then from al-Marwah back to al-Safaa.

In other words, from truthfulness and honesty to compassion, humanity and courage; and from courage towards truthfulness she ran back and forth. Finally, through her sincerity, from a physical point of view – she found the water of *Zamzam*; and from a spiritual point – she found the spring of life. Through her patience and forbearance, struggle and steadfastness, she was able to make the House of Allah an inhabited place and raise the esteem and respect of her offspring.

Although it was a very bitter event from the beginning until the end, it was also very sweet. Bitterness mixed with sweetness and sweetness mixed with bitterness – but what must one do?

Rejoicing is one of the levels or stages of love, and even though it is painful, it is also pleasing. Although the heart of the lover feels pleasure in it, however, from the head to toe of the lover, just like a candle, one burns in the love.

Between the mountains of al-Safa and al-Marwah, we must take the lessons of self-sacrifice and total dedication that Prophet Ibrahim (as) and his companions showed us – leaving away all things for Allah and sacrificing our lives and properties for the religion of Allah.

قَدْ كَانَتْ لَكُمْ أُسْوَةٌ حَسَنَةٌ فِي إِبْرَاهِيمَ وَالَّذِينَ مَعَهُ

“Indeed, there is for you a good example in Ibrahim and those with him.” (60:4).

Therefore, the person who performs the Sa'i between al-Safa and al-Marwah and still has the spirit of egotism and vanity, or the spirit of self-admiration, has in actuality not performed the Sa'i.

Fifth Action: The fifth act is the *taqsir*. The *taqsir* is (the act of) focusing the attention from the spiritual realm to the earthly world; looking from the spiritual pleasures towards the physical pleasures; looking from the oneness to the multitude, which is the characteristic of Islam.

While mankind must be in the constant thought and remembrance of Allah and the Last Day, at the same time, they must also be in remembrance of this world and the needs of this world:

وَابْتَغِ فِيمَا آتَاكَ اللَّهُ الدَّارَ الْآخِرَةَ وَلَا تَنْسَ نَصِيبَكَ مِنَ الدُّنْيَا

‘And seek by means of what Allah has given you the future abode, and do not neglect your portion of this world.’ (28:77).

In the narrations of the Ahl al-Bayt (as) it is been mentioned that one who sacrifices the next world for this world, or one who sacrifices this world for the next world is not a true Shi'a (follower of the Ahl al-Bayt).

Thus, if someone says that the performance of the *taqsir* is to permit things which were previously forbidden – meaning that the things before Ihram which were forbidden for the *muhrim* (the person wearing the Ihram), by wearing the Ihram, performing the Tawaf, Salat, Sa'i between al-Safa and al-Marwah and the taqsir, have now become permitted for him; and the light of Allah has now entered into his heart which before putting on the Ihram was not permitted for him, but after performing the actions (Tawaf, Salat, the Sa'i between al-Safa and al-Marwah and taqsir) have now become permitted for him; seeing deep into the spiritual worlds; attaining to the higher levels of certainty (*yaqin*); the eyes of deep insight which were previously forbidden, by way of the Tawaf, Salat, Sa'i between al-Safa and al-Marwah and the taqsir have now become permitted, then one has not been extravagant in one's speech.

لولا أن الشياطين يحومون على قلوب بني آدم لنظروا إلى ملكوت السماوات والأرض

“Verily, had not the Shaitans hovered around the hearts of the offspring of Adam, they would have been able to see towards the higher realms of the heavens and the earth. “

Sixth Action: Going to (and staying for a fixed period) in *'Arafat* is the next action of the Hajj.

Once a person has seen and been mindful of his one's soul and desires, then once again, with another allure and with another Ihram, one turns the attention towards Allah at a place where the entire spiritual realm has turned towards with complete affinity. Travelling for that lure just as a stallion goes forward towards hay for nourishment; just as the True Entity goes towards the simulated being; an attraction that a lover has with the one he loves. In more passionate terms, it is the attraction between a servant and Allah – and what an attraction it is!

هائنا لارباب النعيم نعيمهم

“Congratulations to the possessors of the Garden of Na'im for their prosperity. “

'Arafah means to gain a deep understanding (*ma'rifah*). A cognition of the beginning (of creation) and the end of all creation; a cognition of Prophethood (*Nubuwah*) and Mastership (*Wilayah*); cognition of the vista of the horizons and of the souls; cognition of all of these things and their relation with Allah (relation of an event (*Hadith*) with the Eternal Being (*Qadim*)); cognition of the guardianship of the Truth, and the absolute destitution of the creation. In summary, attaining the cognition that:

ليس في الدار غيره ديار

“There is no one in the building except for its owner.”

'Arafat is that place where a person is able to focus all of one's concentration on supplication, invocation and Tawassul – especially to *Wali al-Asr* (as) where one is in the presence of our 12th Imam. It is that place where one is able to reach the highest pinnacles of certainty (from *Ilim al-Yaqin* to *'Ain al-Yaqin* and from *'Ain al-Yaqin* to *Haqq al-Yaqin*).

A person who goes to 'Arafat but is not successful in reaching the level of *ma'rifah* that has been mentioned even in a small amount, in reality, has not gone to 'Arafat.

A person who does not attain that closeness to Allah, *Nubuwah* and *Wilayah*, which is what encompasses the entire land of 'Arafat, in reality has done nothing more than put himself through difficulties and troubles in the land of 'Arafat.

Seventh Action: The seventh act is to proceed to *Mash'ar*. The land of *Mash'ar* holds a special place in the sight of Allah, the Most High, such that in the Qur'an it is been given the attribute of being a sanctuary and a place that demands respect:

فَإِذَا أَفْضْتُمْ مِنْ عَرَفَاتٍ فَادْكُرُوا اللَّهَ عِنْدَ الْمَشْعَرِ الْحَرَامِ

“So when you hasten on from Arafat, then remember Allah near the al-Mash'ar al-Haram.”
(2: 198).

In the event that one is present in *Mash'ar* at the time when one should be there (between the time of Fajr and sunrise), which is the best time during a 24 hour period in the sight of Allah and if that which Allah has requested in the Qur'an to be performed – which is the remembrance of Allah in this holy place and at this holy time – then by this remembrance, one will attain intelligence, sagacity, reason and insight.

Faith will be transmitted from one's heart into all parts of the body. The land of *Mash'ar* speaks to us and says, “That which you attained while in 'Arafat must be transported to your heart by the remembrance of Allah; and from the heart, it must be transported to your eyes, ears, tongue and all other parts of the body until your complete presence is given another life.”

That which the soul had achieved in 'Arafat must be seized and controlled. It is here that the World of the Unseen (*Alam al-Ghaib*) becomes the World of the Witnessed (*Alam al-Shuhud*):

الَّذِينَ يُؤْمِنُونَ بِالْغَيْبِ

“Those who believe in the Unseen.” (2:3)

That which once was hidden, now becomes apparent; that which others cannot hear, will be heard; that which others cannot do, one will be able to perform and that which others cannot see, one will be able to visualize. With the eyes of the heart, one will be able to see the power of Allah, the *Nubuwwat* and the *Wilayat* in its true essence. In addition to this, one will also be able to see the Day of Judgement:

عبدني أطعني حتى أجعلك مثلي أقول كن فيكن تقول كن فيكن

“My servant, obey Me, I shall make you like Me. When I say 'Be!', it is – you (too) shall say Be!', and it shall become. “

Eighth Action: The eighth act in the *Hajj* is to proceed on towards Mina. Mina is in the meaning of 'returning' – what a beautiful name! It is said that an aura of light (*nur*) surrounds this area – what a place! A spiritual person's entire existence is surrounded by the light of Allah (swt).

Mina is a place of hopes and aspirations, mercy and forgiveness, nobility and grace. It is a place where one's pleas and supplications are answered, and a place where the good of this world and that of the next world are granted, and why should it not be such? What does the lover want from his Beloved, once he has attained that proximity to Him? Attention, benevolence, benignity, continuation...

After the servant of Allah has passed through 'Arafat and Mash'ar and has reached to the stage of proximity (to Allah), what more can he want from his Master (*Mawla*)? Nobility, mercy, forgiveness, pardon, benignity, the continuation of success until he dies, and to be permitted into the presence of Allah in the next world. For the true lover of Allah, there can be nothing more sensual and pleasing than this.

Thus, it can be said that the most sensual feeling in the Hajj, is the feeling of hope on the part of the servant of Allah – towards Allah Nit in the land of Mind. It may be because of this that out of all the acts of devotion performed during the Hajj, the time spent in Mina is the most, since there is a longing and desire on the part of the servant towards Allah and this is the foremost form of worship (*Ibadah*) and the highest position one can reach.

Ninth Action: The ninth act in the Hajj is to stone the *Jamarah*. The servant who has reached to the stage of closeness to Allah, has arrived to the station of fear, and rightfully so, he must fear!

He has arrived at a place that he must always be fighting against; a place that he must always be aware of, and that is the place of falsehood and despotism, the internal despot – the *al-Nafs Al-'Ammarah*, and the external despot – Shaitan from amongst the Jinn and Mankind.

It is on account of this that the last Surah of the Qur'an has commanded us to seek refuge with Allah

from these despots and from their evil whisperings:

قُلْ أَعُوذُ بِرَبِّ النَّاسِ

“Say: I seek refuge in the Lord of men,” (114:1).

مَلِكِ النَّاسِ

“The King of men,” (114:2).

إِلَهِ النَّاسِ

“The god of men,” (114:3).

مِنْ شَرِّ الْوَسْوَاسِ الْخَنَّاسِ

“From the evil of the whisperings of the slinking (Shaitan),” (114:4).

الَّذِي يُوسْوِسُ فِي صُدُورِ النَّاسِ

“Who whispers into the hearts of men,” (114:5).

مِنْ الْجِنَّةِ وَالنَّاسِ

“From among the jinn and the men.” (114:6).

From the Holy Qur'an, we clearly see that the internal despot (the *al-Nafs Al-'Ammarah*: is the most dangerous of all enemies:

إِنَّ النَّفْسَ لَأَمَّارَةٌ بِالسُّوءِ إِلَّا مَا رَحِمَ رَبِّي

“Most surely (man's) self (Nafs Al-'Ammarah) is habituated to command (him to do) evil, except such as my Lord has mercy upon.” (12:53).

Thus, once we have entered into Mina, the very first act that we must perform is the *Rami* of the *Jamarah al-Uqbah* (the final pillar) which may be a manifestation of the largest despot – the *al-Nafs*

Al-'Ammarah.

The stoning of the *Jamarah al-'Uqbah* represents the rejecting or repudiating of the *al-Nafs Al-'Ammarah*; it represents the act of rubbing of one's low desires and wishes in the dirt.

If one is able to crush the *al-Nafs Al-'Ammarah* during the stoning of the *Jamarah al-'Uqbah*, then one has taken the next step in attaining closeness to Allah, and since between the servant and Allah there is no more than the distance of one step, if one has been able to take this step and make it past one's own low desires and wishes, then that which follows is the level of closeness to Allah.

During those two or three days after the Eid that one is in Mina, one must stone the three *Jamarat*, meaning that one must trample upon his internal despot (*al-Nafs Al-'Ammarah*), the external despot of the Shaitan from the Jinn (Iblis and those like him), and the Shaitan from among the Humans (the enemies of religion and of humanity).

The stoning of the three *Jamarat* is in essence, the trampling upon the despots and waging war against all of them. When one focuses on them and the hatred for them, then one automatically focuses with complete attention upon one's self – and rightfully so – while stoning the *Jamarat*, one must focus entirely upon one's self.

During these two or three days, if one is not able to push away the Shaitan within oneself, then one has done nothing more than put the body through hardships, and in reality, one cannot say that the *Jamarat* in Mina were stoned.

Tenth Action: The tenth act is the *Qurbani* or the sacrifice. The slaughtering of an animal was and still is a tradition among all nations of people, and an act that all religions acknowledge and accept.

In the Qur'an it has been mentioned that *Habil* and *Qabil* (the sons of Adam) had offered a sacrifice, and since one of these sons was a *Muttaqi* (a pious person), his sacrifice was accepted (by Allah).

إِذْ قَرَّبَا قُرْبَانًا فَتُقُبِّلَ مِنْ أَحَدِهِمَا وَلَمْ يُتَقَبَّلْ مِنَ الْآخَرِ وَلَمْ يُتَقَبَّلْ مِنَ الْآخَرِ

“When they both offered an offering, but it was accepted from one of them and was not accepted from the other.” (5:27).

The secret of the *Qurbani* is that one forgets everything and sacrifices (all) in the way of the Loved such that one sacrifices one's own life, property and children. The sacrifice is a symbol of love and commitment; it is a symbol of the acceptance of the personality and the respect one has for one's Beloved:

جان چه باشد که فدا قدم دست کنی

این متاعی است که هر بی سروپایی دارد

*What is it to sacrifice at the feet of the beloved, one's soul,
It is something that everything, little or big, possesses!*

The slaughtering of the animal, just like the Tawaf, has a secret behind it, which is kept between the servant and the Master (*Mawla*). It is one in which the servant and all that one possesses is from Him:

العبد وما في يده كان لمولاه

“The servant and that which is in his possession is (all) for his Master. “

However, more important than this is that the performance of the slaughtering in Mina enlivens that great event between Prophet Ibrahim and Isma'il (as).

The command came from the Beloved that you must slaughter your young child in Mina. Prophet Ibrahim (as) took his young son Isma'il (as) and explained to him what his Beloved had commanded him to do. The young boy entirely, and with full devotion, accepted:

يَا أَبَتِ افْعَلْ مَا تُؤْمَرُ

“O' my father! Carry out that which you have been commanded to do!” (37: 102).

Both of them, with a sense of complete enthusiasm and love, obeyed the command, and at the moment that the knife was on the throat about to slaughter (the young Isma'il (as)), a call was heard from the Beloved that you have successfully completed your test:

قَدْ صَدَّقْتَ الرُّؤْيَا

“You have indeed shown the truth of the vision.” (37: 105).

وَفَدَيْنَاهُ بِذَبْحٍ عَظِيمٍ

“And we ransomed him with a great sacrifice.” (37: 107).

Without doubt, it was a great sacrifice in the way of Allah in which a person had gone to the extreme of almost dying for Allah, but in the end, successfully came out with high marks in the test that Allah had put him through.

What a sweet ending, but what a bitter way to learn! What a trial that the Beloved has mentioned as something great!

إِنَّ هَذَا لَهُوَ الْبَلَاءُ الْمُبِينُ

“Verily this was a manifest trial.” (37: 106).

What was more important than this was the reward that the Beloved blessed them with and that was of being counted as true servants:

إِنَّهُ مِنْ عِبَادِنَا الْمُؤْمِنِينَ

“Verily he was of Our believing servants.” (37: 111).

Therefore, the sacrifice (of an animal) is really a lesson in love; it is a lesson in devotion; a lesson for giving in the way of Allah even so much as one's own life, property and children. It is a lesson in the power of intention during tests and difficulties. It is a lesson in complete submission and true worship to Allah.

Perhaps it is because of this that it can be said that the sacrifice of the animal that is offered in Hajj is the best of acts or at least one of the best acts.

Eleventh Action: The eleventh act is the *Halq* (shaving off the hair on the head) or the *Taqsir* (trimming the hair or nails).

Shaving the hair on the head or trimming the hair of the head or beard, symbolizes the removing of all that remains (in the soul); removal of the bad traits; purifying the heart of all traces of vanity or egotism; and the removal of love for seeking a high status (in society).

Whatever a person does to try and build one's self and ethics, one must know that the roots of the negative attributes are centered deep down in the heart of a person:

آخر ما يخرج عن قلوب الصديقين حب الجاه

“The last thing that will come out of the hearts of the truthful (people) is the love of status.”

Thus, shaving the head or cutting a bit of the hair on the head or face has its foundations in removing the negative attributes of a person.

If a person performing the Hajj has not reached the level in which one has expelled everything from the

heart, then one should know that one has scored a zero in this test from Allah even though having gone through difficulties and troubles!

An accepted Hajj is a Hajj in which after shaving the head or trimming the hair of the head or face, one also shaves one's heart of hardness and corrects one's conduct.

Although the acts of Hajj in their apparent form are all great forms of worship in Islam and denying them leads one to the state of disbelief (*Kufr*), however in reality, they are all teachers of etiquette (*Akhlaq*).

These are acts which train the person performing the Hajj how to build one's self and aid one in travelling from the darkness of negative attributes, the darkness of the *al-Nafs Al-'Ammarah*, from those of one's vain and lower desires, and the darkness of sadness, anger and anxiety of the heart into an ocean of *pure light (al-Nur al-Mutlaq)*.

They are acts that take the person by the hand and guide one from the station of repentance and vigilance to the station of expelling (all from the heart).

One goes from this stage to the level of reaching close to Allah, and this last act (of the Halq or Taqsir) also makes certain things permitted (*halal*) after they were made prohibited (*haram*). Although its apparent meaning is that those things which were forbidden are now permitted; however, for the spiritual person, its meaning is that those things which were previously not worthy of being committed, are now worthy of performing. (The manifestation of the *Nur of Allah* in the heart and the power over possession in creations (are two of the outcomes of the twelfth act of the Hajj) – however, more important than these two is the power of choice in the tests that one is put through by Allah.)

Twelfth Action: The twelfth act is the *Tawaf an-Nisa*. After performing the *Halq* or *Taqsir*, many things which were forbidden for the one performing Hajj now become permitted – except for the use of perfume and all pleasures one derives from the opposite sex.

The only way that these two are made permissible is that after Mina, one returns to the House of Allah and performs the Tawaf, Salat of the Tawaf, Sa'i between the mountains of al-Safa and al-Marwah, and then performs the final Tawaf known as Tawaf an-Nisa, such that then perfume and all sexual relations become permissible for one.

Perhaps one of the secrets behind this is that no matter what level a human reaches to in witnessing the manifestation of the greatness of Allah, however, in order to gain authority over one's sexual instincts, one is still in need of reaching to an even higher station and is in need of more assistance.

وَلَقَدْ هَمَّتْ بِهِ وَهَمَّ بِهَا لَوْلَا أَنَّ رَأَى بُرْهَانَ رَبِّهِ

“And certainly she made for him, and he would have made for her were it not that he had seen

the manifest evidence of his Lord.” (12:24).

In all the examinations that Yusuf the Truthful went through one after the other, he came out with passing marks, even when the group of women with their apparent beauty, which in reality was their lack of modesty, tried to seduce him. He replied: ‘O’ Allah! The prison is better for me than what these women say!’:

رَبِّ السِّجْنِ أَحَبُّ إِلَيَّ مِمَّا يَدْعُونَنِي إِلَيْهِ

“My Lord! The prison is dearer to me, than that to which they invite me.” (12:33).

However, it was this same Yusuf (as) that even though the status that he was at and while scoring high marks in his examinations (from Allah), but when put face to face with his sexual instincts, he showed his weakness or inability. He said that it was Allah who saved him, not himself, and that if He were not there, he would have failed the exam:

وَأِلَّا تَصْرِفْ عَنِّي كَيْدَهُنَّ أَصْبُ إِلَيْهِنَّ وَأَكُن مِّنَ الْجَاهِلِينَ

“And if Thou turn not away their device from me, I will yearn towards them and become (one) of the ignorant.” (12:33).

Therefore, in reality there is a great lesson for all of us – especially the youth – in the Tawaf an-Nisa. If we want to remain guarded from the evils of our sexual instincts, then in addition to controlling them through the power of intention that we possess and by satisfying them through the sound and approved Islamic methods, we must also ask for assistance from Allah and seek help through the religious acts of pleasure such as Tawaf an-Nisa.

Thirteenth Action: The thirteenth and final act of the Hajj is going to the city of *Madinatul Munawwarrah* and performing the visitation rites (*Ziyarat*) of the Noble Prophet Muhammad (s), Fatimah az-Zahra (sa) and the A'immah (as) that are buried in the graveyard known as *Jannatul Baqi*. The performance of the Hajj is incomplete without the Ziyarat of these noble personalities and can be compared to one holding firm to the Holy *Qur'an*, but not having belief in the *Wilayah*.

It has been mentioned in the narrations from the Ahl al-Bayt (as) that the performance of Ziyarat in *Madinatul Munawwarrah* is the actual completion of the Hajj. As well, in the Holy *Qur'an*, *Tawassul* or seeking help from the Ahl al-Bayt (as) has been made compulsory on us:

يَا أَيُّهَا الَّذِينَ ءَامَنُوا اتَّقُوا اللَّهَ وَابْتَغُوا إِلَيْهِ الْوَسِيلَةَ

“O' you who believe! Be careful of (your duty to) Allah and seek a means of nearness (intermediary) to Him.” (5:35).

The best form of seeking help or *Tawassul*, is the recitation of supplications (*Dua*) and seeking forgiveness for one's sins while inside the holy sanctuaries of these personalities and this in reality, is supplicating and asking forgiveness as though in their presence.

The Creator and Maintainer of the Universe will only accept the supplications and asking of forgiveness with the condition that it be done in the presence of these holy personalities (the Noble Prophet of Islam (s) and his Ahl al-Bayt (as))

وَلَوْ أَنَّهُمْ إِذْ ظَلَمُوا أَنفُسَهُمْ جَاءُوكَ فَاسْتَغْفَرُوا اللَّهَ وَاسْتَغْفَرَ لَهُمُ الرَّسُولُ لَوَجَدُوا اللَّهَ تَوَّابًا رَحِيمًا

“And had they, when they were unjust to themselves, come to you (Muhammad) and asked forgiveness of Allah, and had the Messenger (also) asked forgiveness for them, they would have found Allah Oft-returning (to mercy), Merciful.” (4:64).

Bearing this in mind, we see from the ahadith of the Ahl al-Bayt (as) that visitation to the graves of the members of the Ahl al-Bayt (as) has been emphatically recommended.

Fatimah az-Zahra (as) had said: “Paradise will become incumbent upon the person who performs the Ziyarat of Rasul Allah (s).”

In many other ahadith we read that the Ziyarat of Prophet Muhammad (s) is equal to the Ziyarat of Allah Himself!

In one hadith, it has been mentioned that the Noble Prophet Muhammad (s) told Amir al Mu'minin 'Ali (as) that:

“The graves of the Ahl al-Bayt are gardens from Paradise. Allah (as) the Maintainer of the Universe, has placed the love and yearning to visit these graves in the hearts of a select group of His servants and on the Day of Judgement, they will be at the Fountain-head of Kawthar, enjoying my special intercession. In Paradise, they will be my neighbours.

The reward of performing seventy recommended (*mustahab*) Hajj is written for such a person, and after the Ziyarat, one's sins are completely washed away like one who was just born from one's mother.

In Paradise, there is a station for these people such that no one else will be able to grasp the greatness of it. However, there are insignificant people who make fun of our visitors, and these ones are the worst people of my nation. They will never attain my intercession nor will they meet me at the Fountain of Kawthar!”

There are a few things that must be observed by that person who has been graced with the extraordinary honour of visiting the graves of the Prophet or his Ahl al-Bayt (as):

1. They must be aware of whose presence they are in, and know that their speech, actions, thoughts and even intentions are all presented to these holy personalities:

وَقُلْ اَعْمَلُوا فَسَيَرَى اللّٰهُ عَمَلَكُمْ وَرَسُولُهُ وَالْمُؤْمِنُونَ

“Say: Work: so Allah will see your work and (so will) His Messenger and the believers.” (9: 105).

Thus, one must enter the sacred sanctuary with a pure heart, sincere intention and observe the proper etiquette of speaking and acting. It may be possible that reciting the salutations (*Ziyarat*) in a loud voice may not be appropriate, nor would speaking with others:

لَا تَرْفَعُوا اَصْوَاتَكُمْ فَوْقَ صَوْتِ النَّبِيِّ

“Do not raise your voices over the voice of the Prophet!” (49:2).

The etiquette related to sitting and standing must also be observed while in this place – just as one, during the lifetime of these holy personalities would sit (and stand). Of course – pressing one's body against the blessed enclosure (*dharīh*), kissing it and the walls of the rooms and the sanctuary is an outward show of love that each lover must perform.

این سگ فرخ رخ نیل است این

پاسدر کوجه لیلی است این

Majnun has said that the door and walls of the city that Laila lives in are kissed by the dog that guards the alley where Laila is and says that (he does this because) Laila is present in this city.

2. One must prepare to enter the Sanctuary (*Haram*) in order to attain the spiritual blessings, in other words, to connect oneself spiritually (with the holy personality).

How beautifully ‘Allamah Majlisi has said it! He relates, ‘I went to *Najaf al-Ashraf* and since I did not have spiritual desire to go inside the Haram for a few days, I spent my nights in the sacred courtyard, and spent my days in the graveyard of *Wadi as-Salam* near the *Maqam (Station) of al-Qa’im* (as). I practiced religious self-discipline until I reached the level of attaining divine inspiration and enlightenment (and then entered the Haram).’

3. Paying attention to the fact that sins, especially those which are referred to as *Haqq al-Nas* – the sins which are related to other people – cause agony to the hearts of the Ahl al-Bayt (as). In many narrations we read that the A'immah (as) had said that oppression to our Shi'a is equivalent to oppressing us.

Thus, if we want to please the Ahl al-Bayt (as), then we must make a firm resolve that we will never turn away from helping and aiding other Shi'a. We must also make a firm resolve that we will not oppress or ridicule any of their friends. After making this resolution and asking forgiveness, we enter their sanctuary.

4. One's motivation must be high, and he must not limit himself to simply asking for things of this world and the next. Rather, these requests should be left to them (to decide for us):

علمهم بحالنا من سؤالنا

“Their knowledge of our condition suffices us from our asking (them) “

Further, one's request and desire must be that their light (*nur*) should be graced upon us.

One must rely upon the leadership of the physical world (*Wilayah Takwini*) that they possess so that we can be elevated (in status).

One is able to reach the level of meeting with Allah and complete annihilation with a few things: *Buraq* for use in ascending; provisions and supplies for the road; a guide so as to not get lost and reach the appropriate place; and light (*Nur*) to act as a torch while passing through the levels of darkness.

For a person, the *Buraq* (stead) on this trip is one's human presence, which is the body. In order to increase the power of this *Buraq*, the Qur'an has recommended us that:

وَابْتَغِ فِيمَا آتَاكَ اللَّهُ الدَّارَ الْآخِرَةَ وَلَا تَنْسَ نَصِيبَكَ مِنَ الدُّنْيَا

“And seek by means of what Allah has given you the future abode, and do not neglect your portion of this world.” (28:77).

One's provisions and supplies for this trip are piety (*taqwa*) and a soul that truly fears Allah, which according to the Qur'an are the best supplies for a trip:

وَتَزَوَّدُوا فَإِنَّ خَيْرَ الزَّادِ التَّقْوَى

“And make provision, for surely the best provision is the guarding of oneself.”(2: 197).

The light (*Nur*) which a person must take on this trip, so as to save himself oneself from darkness is the

Qur'an:

قَدْ جَاءَكُمْ مِنَ اللَّهِ نُورٌ وَكِتَابٌ مُبِينٌ

“Indeed, there has come to you light and a clear Book from Allah.” (5:15).

The guides to this light (*Nur*) are the Ahl al-Bayt (as). Without them, there is not a single creature that can ever reach to perfection, nor can they reach to the level of connection (with Allah).

Any person who does not take guidance from them while engaging on the path of *sair wa suluk* (*Spiritual travel & journey towards Allah*), instead of reaching to a level of connection (with Allah), will actually cut off the connection (with Allah), and in place of guidance, will fall into darkness and misguidance.

From the point of view of the Qur'an, those responsible for guidance towards this path are the Ahl al-Bayt (as). During our present time, the axis of the world of possibility (*al-Alam al-Imkan*), the pivot of the world of creation, and the intermediary between the unseen and witnessed (*ghaib wa shuhud*) is Imam Wali al-'Asr (as).

وَجَعَلْنَاهُمْ أَئِمَّةً يَهْدُونَ بِأَمْرِنَا

“And We made them Imams who guided (people) by Our command.” (21:73).

Therefore, *Tawassul* is one of the necessities, and the best form of *Tawassul* is to visit the sacred graves (*Ziyarat*) of them (the Ahl al-Bayt (as)); and further, if one is fortunate enough, then to be at the service of Imam Wali al-'Asr' (as).

Imam 'Ali ibn Musa al-Ridha' (as) has said that every Imam has an oath or pledge binding on the neck of every Shi'a and true lover, and the best way of showing one's loyalty to this pledge or oath is to visit their graves.

Any of the Shi'a that perform the *ziyarat* of them (the Ahl al-Bayt (as)) will receive their intercession on the Day of Judgement; and visiting their graves will guide one in this world as well as in the next life.

The Third Stage of the Hajj

Third Stage: The third stage is going from Makkah and Madinah back to one's hometown.

سير من الحق إلى الخلق

The responsibilities at this stage are much more difficult than they were at the first and second level, since it is at this level that one's responsibilities become just like those of the Prophet of Allah:

الَّذِينَ يُبَلِّغُونَ رِسَالَاتِ اللَّهِ

“Those who convey the messages of Allah.” (33:39).

In the first and second stage, one was busy with self-building, but at this stage, one must work on building others. Although the act of enlightening others is dependant upon self-building, however, this task is so difficult that the Noble Prophet Muhammad (as) has said:

« شيبتني سورة هود لمكان قوله: «فَاسْتَقِمْ كَمَا أُمِرْتَ وَمَنْ تَابَ مَعَكَ

“Surah Hud made my beard white from the point where it was revealed, **‘Continue then in the right way as you are commanded, as also he who has turned (to Allah) with you (O’ Muhammad) (11:112)’**” .

Self-building has also been mentioned in Sarah al-Shuara where it says:

فَاسْتَقِمْ كَمَا أُمِرْتَ

“Continue then in the right way as you are commanded.” (26: 15).

However, that which caused the beard of the Prophet to turn white was the command to build others:

وَمَنْ تَابَ مَعَكَ

“...as also he who has turned towards Allah with you (O’ Muhammad).” (11:112).

After returning from Makkah and Madina, the Hajji must convey that which he has brought with him (his self-building) to others through his actions. His speech, actions, manner and disposition must be an example for others, and this is truly the best gift that one can bring back for the rest of the people.

The Hajji must inform others of the importance of Salat by performing it right when the time sets in, reciting it in the Masjid, in congregation (*Jama'at*), and paying attention to the overall importance of it.

Without doubt, that *Hajji who* is not concerned about the Salat, such that the time for it sets in, but one is absorbed in making a living, has truly not experienced the Hajj. The Qur'an speaks to people like this and curses them by saying: 'Curse be on you – you are not a Hajji –rather, you are not even a Muslim!'

فَوَيْلٌ لِلْمُصَلِّينَ الَّذِينَ

“So then woe to those who pray” (107:4).

هُمْ عَنْ صَلَاتِهِمْ سَاهُونَ

“those of them who are heedless of the Salat.” (107:5).

Paying attention to all of the acts which are obligatory (*Wajib*), namely paying *Khums* and those things which are forbidden such as not taking interest, not taking bribes, not selling less than what one takes money for, not selling things for more than their worth, not to hoard or cheat in business transactions and... are some of the traits that one must bring back from the Hajj as gifts.

One must enliven into the hearts of others things such as paying importance to those acts that are obligatory and staying away from sins.

That Hajji who after returning from Hajj stops paying *Khums* is not only not regarded as a Hajji, but from the point of the Qur'an, is a polytheist (*Mushrik*) and a disbeliever (*Kafir*):

وَوَيْلٌ لِلْمُشْرِكِينَ الَّذِينَ لَا يُؤْتُونَ الزَّكَاةَ وَهُمْ بِالْآخِرَةِ هُمْ كَافِرُونَ

“And woe to the polytheists: those who do not give poor-rate and do not believe in the hereafter.” (41:6-7).

The woman who has just returned from Makkah and Madinah after the Hajj must improve her hijab, and make it the same as the hijab of Fatimah az-Zahra (as) so that her covering is an example and model not only for herself, but also for others.

That woman who has gone to Makkah but returns without the gift of the hijab of Fatimah az-Zahra (as) for others and continues to wear her hijab in a wrong manner, or does not wear the hijab at all, has trampled over more than ten verses of the Qur'an and her Hajj was nothing more than troubles to herself.

Yes! The Muslim man and woman, after completing the Hajj must through his and her Islamic etiquette – both amongst their household and amidst the people – be practical propagators of the faith.

Forgiveness and absolution, dedication and sacrifice should be their mottoes and others must be able to benefit from these maxims, just as the Qur'an has repeatedly mentioned:

لِيُنْفِقْ ذُو سَعَةٍ مِّنْ سَعَتِهِ وَمَن قُدِرَ عَلَيْهِ رِزْقُهُ فَلْيُنْفِقْ مِمَّا آتَاهُ اللَّهُ

“Let him who has abundance, spend out of his abundance and whoever has his means of subsistence straitened to him, let him spend out of that which Allah has given him.” (65:7).

The Hajji must be an example for others. How difficult this third level truly is, however the rewards are just as great!

مَنْ أَحْيَاهَا فَكَأَنَّمَا أَحْيَا النَّاسَ جَمِيعًا

“And whoever keeps (one person) alive, it is as though he kept alive all of mankind.” (5:32).

The one thing that a man and woman who have returned from Hajj must always keep in mind at the third stage is that the Hajjis accountability before Allah, the Ahl al-Bayt (as) and the people is much different than that of the accountability that the 'common people' have.

For the Hajji, Allah and the Ahl al-Bayt (as) open another 'book of accounts' in the same way that the common people look at the one who has returned from Hajj in a different light.

Prophet Adam (as), did nothing more than a *tark-e-Awla* (not performing something that was better, rather performing something good' in its place), but since he was one of the 'chosen' people and this *tark-e-Awla* was not appropriate for one with such a holy spirit, thus he was addressed as such:

اهْبِطُوا بَعْضُكُمْ لِبَعْضٍ عَدُوٌّ

“Get down from here (you two), one of you being an enemy to the other.” (2:36).

He was expelled from that high status (*Jannah*) to the lower status (*this world*).

Even with the status and position that Prophet Yusuf the Truthful (as) held, and with all the high marks that he scored in his tests, still he spent close to ten extra years in prison just for seeking help from other than Allah (swt).

فَلَبِثَ فِي السِّجْنِ بِضْعَ سِنِينَ

“So then he spent some more years in the prison. “ (12:42).

Prophet Yusuf (as) did not commit a sin, since he was immune from committing sins (*ma'sum*), but it was this *tark-e-Awla* that he performed which was not befitting for one at his status, and thus he was forced to spend an ten extra years in prison.

There are many more stories like this in the Qur'an that are examples for the men and women who have returned from Hajj.

If a woman who has returned from Hajj – through her actions and the way she carries herself or by not wearing the hijab or not observing it in the proper way, lowers the (value of the) Hajj amongst the people, then her sin is so great, that it is beyond our comprehension whether repentance can absolve her (of her sin) or not.

If a man, through his etiquette and not staying away from sins, especially those which are the *Haqq a/Nas* meaning those sins which are related to the rights of others, or through not paying proper attention to the Salat, or utter disregard of the Mimbar and Mihrab such that the people consider what he is doing to be permitted, leads the people to think that this Hajji has returned from Allah however (due to his actions) the magnificence of the Hajj is removed from their hearts, then his sin is so great that the Qur'an mentions that it is comparable to murdering all of humanity:

مَنْ قَتَلَ نَفْسًا بِغَيْرِ نَفْسٍ أَوْ فَسَادٍ فِي الْأَرْضِ فَكَأَنَّمَا قَتَلَ النَّاسَ جَمِيعًا وَمَنْ أَحْيَاهَا فَكَأَنَّمَا أَحْيَا النَّاسَ جَمِيعًا

“Whoever slays a soul, unless it be for manslaughter or for mischief in the land, it is as though he slew all men; and whoever keeps it alive, it is as though he kept alive all men. ” (5:32).

In the completion of our discussion, I would request every man and woman who has been blessed with this great opportunity, and who is now being addressed with the name ‘*Hajji*’ that each and every day you read the above mentioned noble verse of the Qur'an to yourself, and remember the meaning of the verse just as Imam Ja'far as-Sadiq (as), has taught it.

Make yourself a living example of this noble verse of the Qur'an (the verse quoted above), continuously repeat it, and say to yourself

مَنْ قَتَلَ نَفْسًا بِغَيْرِ نَفْسٍ أَوْ فَسَادٍ فِي الْأَرْضِ فَكَأَنَّمَا قَتَلَ النَّاسَ جَمِيعًا

I am that person which, from the view point of the Qur'an and the explanation of Imam Jafar as-Sadiq (as) that if I give life to one person through my speech, acts or performance in propagation (of the religion), then I am like as that person who has saved the entire humanity.

However, if through my speech, actions or the way I carry myself, I cause even one person to be lead astray, and have reduced the (worth of the) Hajj, and reduced the (worth of the) religion in that person's

heart, then and I am just like person who has killed all of those in the world.'

I pray to the Maintainer of the Universe for the success of everyone in this spiritual and celestial travel (performing the Hajj in its true essence) under the shadow of the close watch of Imam Wali al-Asr, may Allah (SWT) hasten his noble return.

Husain Mazaheri

Talbiyyah upon wearing the Ihram

،لبيك اللهم لبيك

،لبيك لا شريك لك لبيك

،إن الحمد والنعمة لك والملك لا شريك لك لبيك

،لبيك ذا المعارج لبيك

،لبيك داعيا إلى دار السلام لبيك

،لبيك غافر الذنوب لبيك

،لبيك أهل التلبية لبيك

،لبيك ذا الجلال والكرام لبيك

،لبيك تبتدىء والمعاد إليك لبيك

،لبيك تستغني ويفتقر إليك لبيك

،لبيك مرهوبا ومرغوبا إليك لبيك

،لبيك إلى الحق لبيك،

،لبيك ذا النعماء والفضل الحسن الجميل لبيك،

،لبيك كشاف الكرب العظام لبيك،

،لبيك عبدك وابن عبدك لبيك،

!لبيك يا كريم لبيك

“I am present, O' Allah, I am present. I am present, no partners do you have, I am present. Verily the Praise and Bounties and the Kingdom is for you, no partners do you have. I am present, O' High, I am present. I am present, O' one who calls towards Heaven, I am present. I am present O' Forgiver of sins, I am present. I am present O' One who owns my presence, I am present. I am present

O' Mighty and Generous, I am present. I am present O' You who first created and to whom all will return, I am present. I am present O' One who is free from want and to whom all turn for their needs, I am present. I am present O' who is feared and to whom there is inclination, I am present. I am present, O' true God, I am present. I am present O' the One with Grace, Excellence, Goodness and Beauty, I am present. I am present O' one who averts major calamities, I am present. I am present Your servant and the son of Your servant, I am present. I am present O' Generous, I am present.”

Sketch of the Ka'bah and Sections Related to

the Hajji

Sketch of the Ka'bah and Sections Related to the Hājji

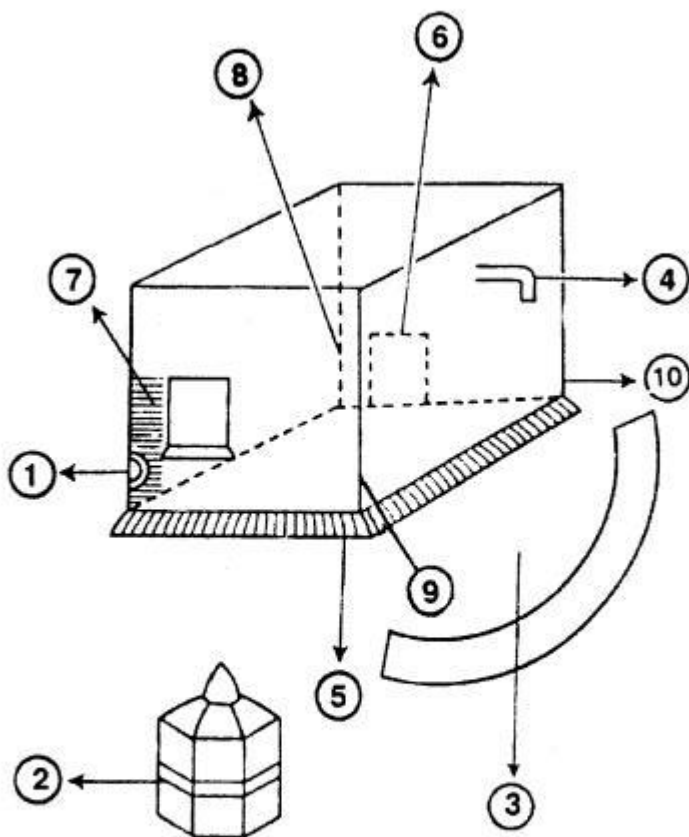

[1] Hajar al-Aswad	[6] Mustajar
[2] Maqām Ibrāhīm	[7] Hatwim
[3] Hijr Ismā'il	[8] Al-Rukn al-Aimāni
[4] Mizāb al-Rahmah	[9] Al-Rukn al-Iraqi
[5] Shadharwan	[10] Al-Rukn al-Shāmi

1. The Black Stone

Start and finish your Tawaf at the Black Stone. The Holy Prophet says that he who does Tawaf of the House at noon with his head bare, bare-foot, making his steps short, closing his eyes (overlooking, disregarding others) and touching the Black Stone in every round he makes, without hurting anyone nor cutting short his praise and glorifying of Allah, will be rewarded for each step he makes with seventy thousand good deeds. Seventy thousand of his evils will be wiped off; his rank will be increased by seventy thousand grades; he will be given the reward as if seventy thousand slaves, each whose price is ten thousand dirhams were freed on his behalf; seventy of his family members would be cured of any sickness, and seventy thousand of his needs would be granted –sooner or later.

The Holy Prophet (s) said: *“Touch the corner (in which the Black Stone rests) for it is the right hand of*

Allah amongst his creation with which he greets His servants a greeting of a slave (or man). It will be witness to the loyal. “

It is recommended to kiss it, if not possible touch it; and if not possible then to point at it (make a gesture).

2. Maqam Ibrahim

Allah says: *“Appoint for yourselves a place for prayer on the standing place of Ibrahim. “* It is enough to note that the preference of this place is symbolized by bearing the name of this great Prophet. His rank is one of the most perfect due to the fact that he spent the whole of his life, his family's and the whole of his wealth for the sake of Tawhid and keeping firm Allah's signs by building the Ka'bah at the centre of His House.

3. Hjr Isma'il

This is his (Isma'il's) house. He and his mother were buried in there. Halabi narrates from Imam as-Sadiq (as) saying: *‘ I asked him concerning Hjr Isma'il and said: You call it the smashed (smasher) but it was for Isma'il's sheep (and goats). His mother was buried in there and denied access to anyone, for he did not like it to be walked on. “* Other Prophets are buried in this place also.

Imam al-Baqir (as) said: *“The place (around) between the Rukn (corner) and the Maqam is full of graves of Prophets”* Imam Sadiq (as) says that seventy prophets were buried between Rukn al-Aimani and Hajar al-Aswad. As such, when at this place, you should perform the Ziyarat of Isma'il, his mother and the prophets

It is recommended to put on Ihram of Hajj at-Tamattu' at the Hjr facing Mizab al-Rahmah which is a place of supplication and asking for Allah's Mercy.

4. Mizab ar-Rahmah

It is recommended to face the Mizab and supplicate as narrated by 'Ayyub from Imam Musa ibn Ja'far (as) which can be found in the various books of supplication related to the Hajj.

5. Shadharwan

This is the remaining part at the foundation of the House's wall.

6. Mustajar

The place which is opposite the Ka'bah is called Mustajar, Mutawwadh or Multazam. There are many

traditions in preference of the place. Imam 'Ali (as) says: “Confess in recognition of the sins you recall at Multazam.”

It is narrated that he who does this and repents for all his sins, Allah will definitely forgive him. In one of the books, it is said that at Multazam, Imam Sadiq (as) used to tell his companions to give him time that he could confess and disclose his “sins” to his Lord saying that the place was of a very high spiritual preference.

In another tradition it is said that when Prophet Adam (as) was at this place, the Angel Jibra'il told him to disclose his “sins” to the Lord. Prophet Adam (as) did so and his “sins” were forgiven. Prophet Adam (as) then asked Him to forgive his son(s) (or his descendants) for their sins. Allah answered back saying that He could only forgive those who went and repented at that spot.

It is recommended for one in his seventh round or after Tawaf to spread out his hands, touch, and let his body and cheek touch the House and recite the supplications that Imam Sadiq (as) used to recite in this place.

7. Hatwim

This is the place between the door of the Holy Ka'bah and Hajar al-Aswad. It is one of the holy places and it is upon one to ask for forgiveness at this place. He should pray, supplicate and cling to the curtains of the Ka'bah for at this place, great and major sins are completely destroyed and smashed. This is the reason of calling the place by this name *smasher*. In other traditions it is said that it is the place where Adam (as) was forgiven of his sins.

8. al-Rukn al-Aimani

The place opposite the Black stone behind the House is the one is called al-Rukn al-Aimani (the right-hand side corner). There are many traditions that have been narrated in preference of this place to an extent that perplexes and boggles the mind. The Holy Prophet said: *“Whenever I come to at this point I find that Jibra'il is already there before me.”*

Imam Ja'far (as) said: *“The Rukn al-Aimana is our gate to paradise.”*

He also said: *“In this place, is one of the doors of paradise that has never been closed since it was opened. There is a river from paradise in which deeds of the servants are dropped.”* He continued by saying: *“There is an angel who has been stationed at this point since the creation of the heavens and the earth whose duty is nothing other than to take care of your supplications. As such one must be careful with what he is saying. One should make use of his presence at this holy place as Possible and should not waste time doing things that are of less importance.”*

9. al-Rukn al-Iraf

This corner is named as such since it faces towards Iraq – south east.

10. al-Rukn al-Shamh

It is recommended to touch all the corners according to the narration from Jamil bin Salih that he saw Imam Sadiq (as) touching them all.

All the same, it is stressed to touch Rukn al-Aimani and the corner where the Black Stone rests. It is understood from traditions that the Holy Prophet; used to touch them all. Of course, all this depends on the fact that you don't disturb other people around you otherwise the recommended act loses authenticity and if anything it could even be haram (forbidden).

The Rukn al-Sharqi (Eastern Corner) is where the Black stone rests while Rukn ash-Shimali (Northern Corner) is the one which comes after the Holy Ka'bah's door before reaching Hijr Isma'il. It is well known as Rukn al-Iraqi (it is also called Rukn ash-Shami).

Rukn al-Gharbi (Western Corner) is the one that comes after Hijr Isma'il (also called Rukn ash-Shami).

Rukn al-Junubi (Southern Corner) is the one that comes before the Black Stone corner (also known as Rukn al-Aimani).

Image:

Sketch of the Ka'bah and Sections Related to the Hājjī

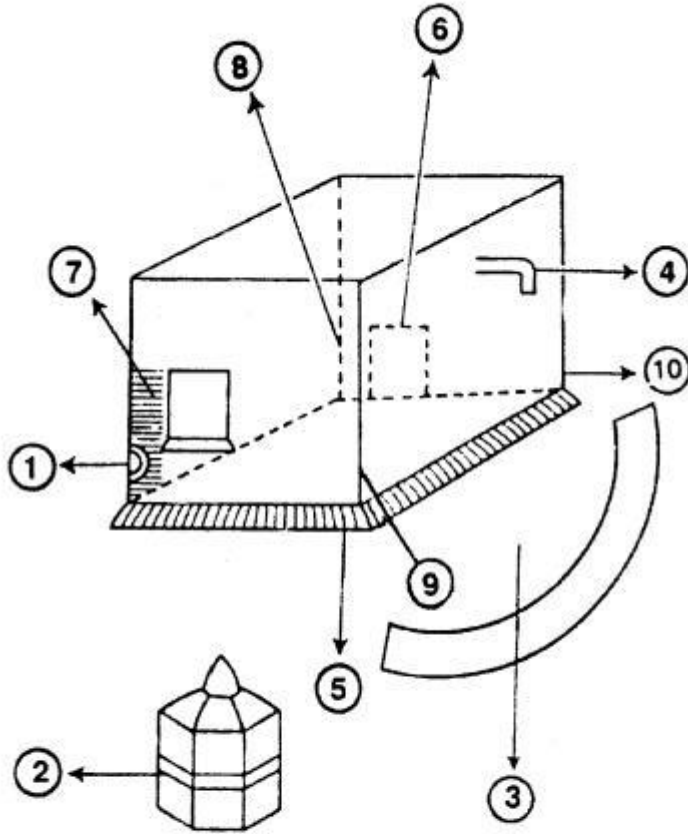

[1] Ḥajar al-Aswad	[6] Mustajar
[2] Maqām Ibrāhīm	[7] Hatwim
[3] Hījr Ismā'il	[8] Al-Ruknīl Aīmānī
[4] Mizāb al-Raḥmah	[9] Al-Ruknīl Irāqī
[5] Shadharwan	[10] Al-Ruknīl Shāmī

Sketch of Jannatul Baqi and the Graves of the members of the Ahl al-Bayt

Sketch of Jannatul Baqi and the Graves of the Members of the Family of the Prophet as well as Renowned and Revered Companions

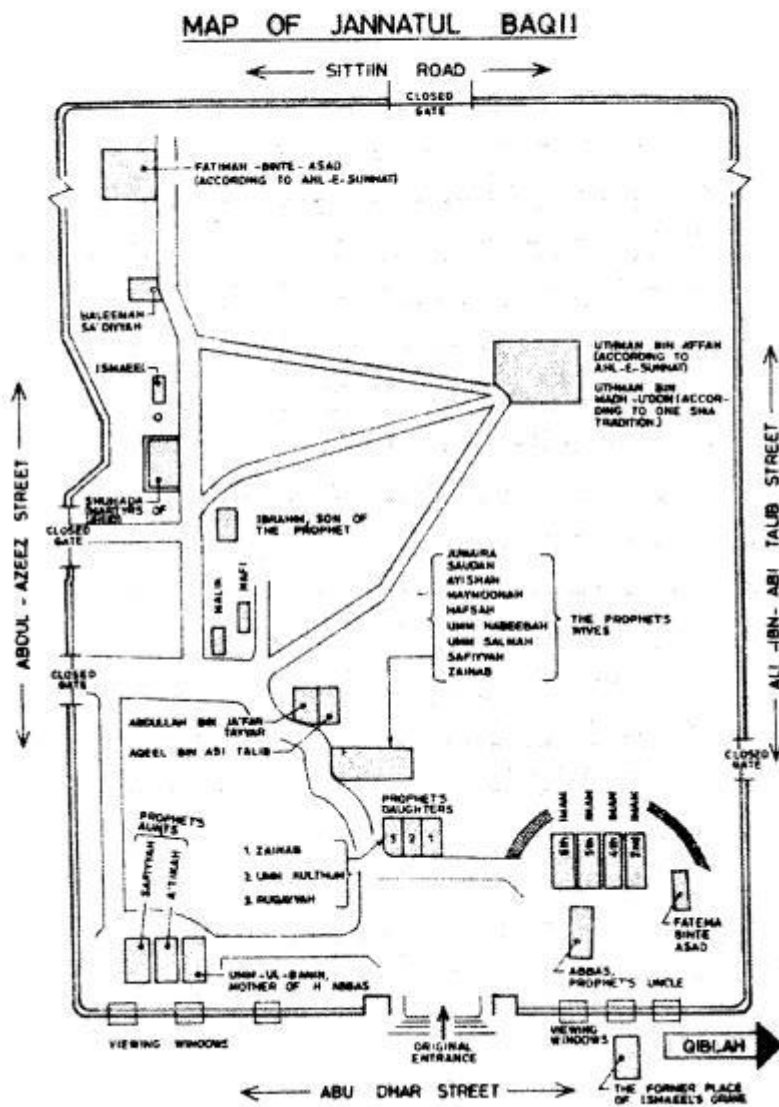
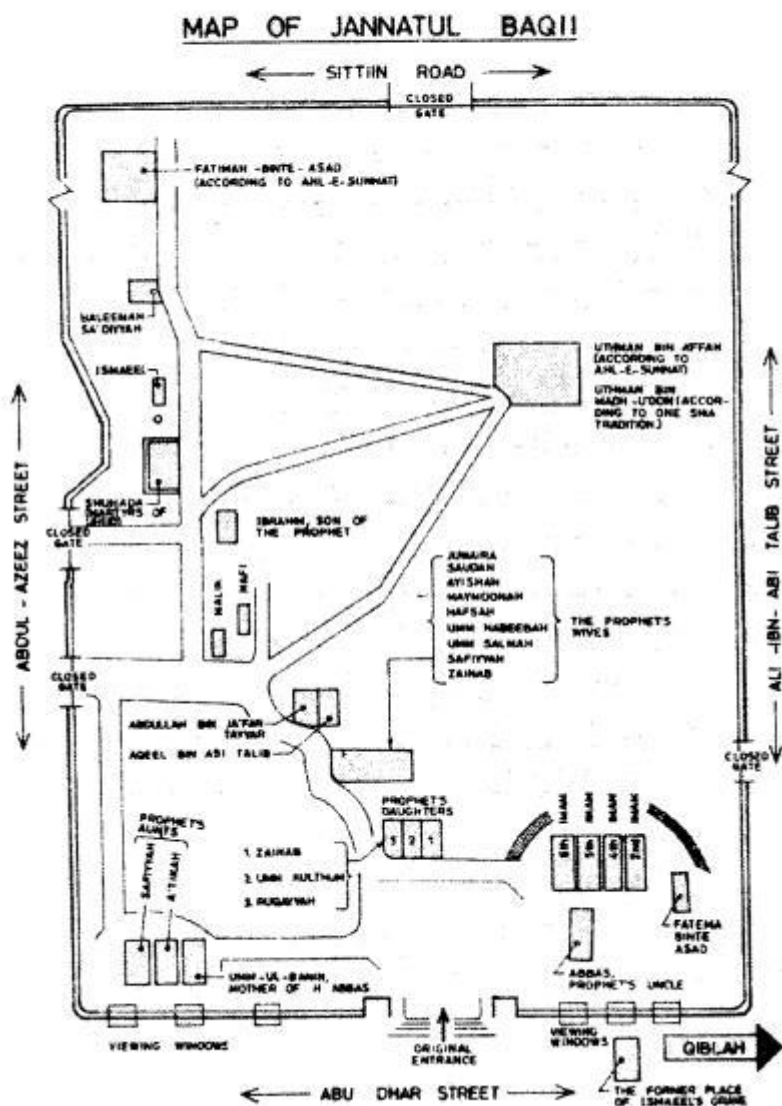

Image:

Sketch of Jannatul Baqi and the Graves of the Members of the Family of the Prophet as well as Renowned and Revered Companions



Sketch of Makkah, Masjid al Haram and some of the Surrounding Sites

Sketch of Makkah, Masjid al-Harām and some of the Surrounding Sites

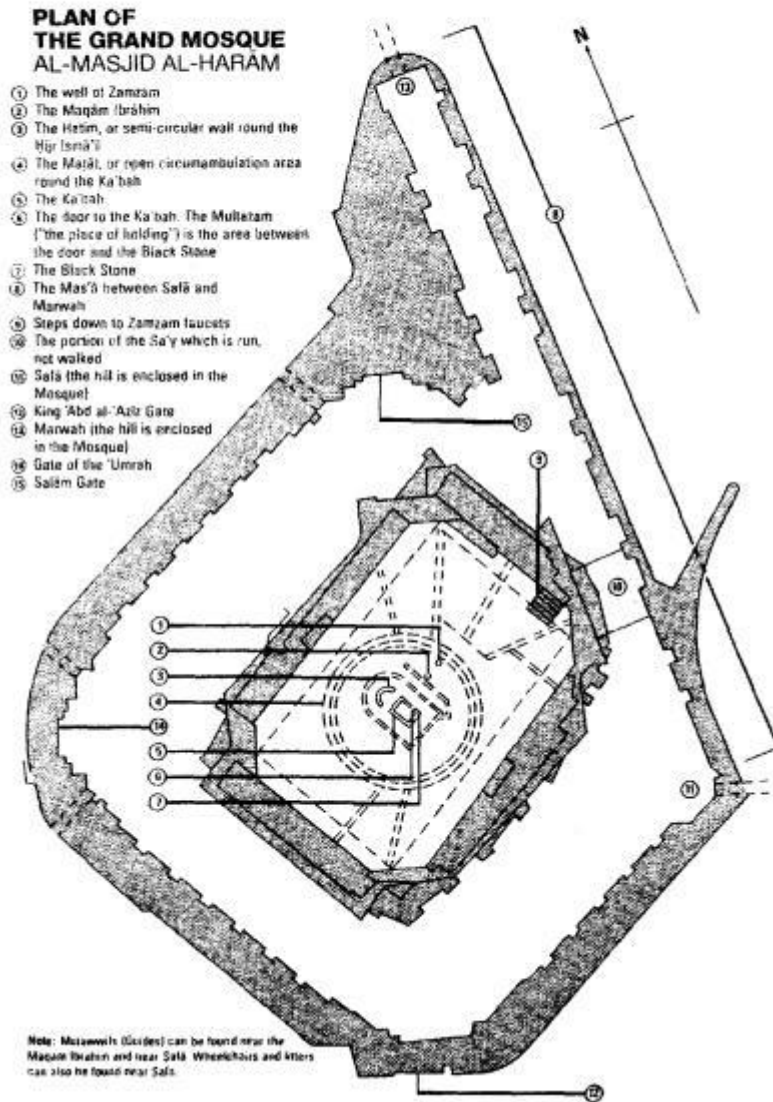
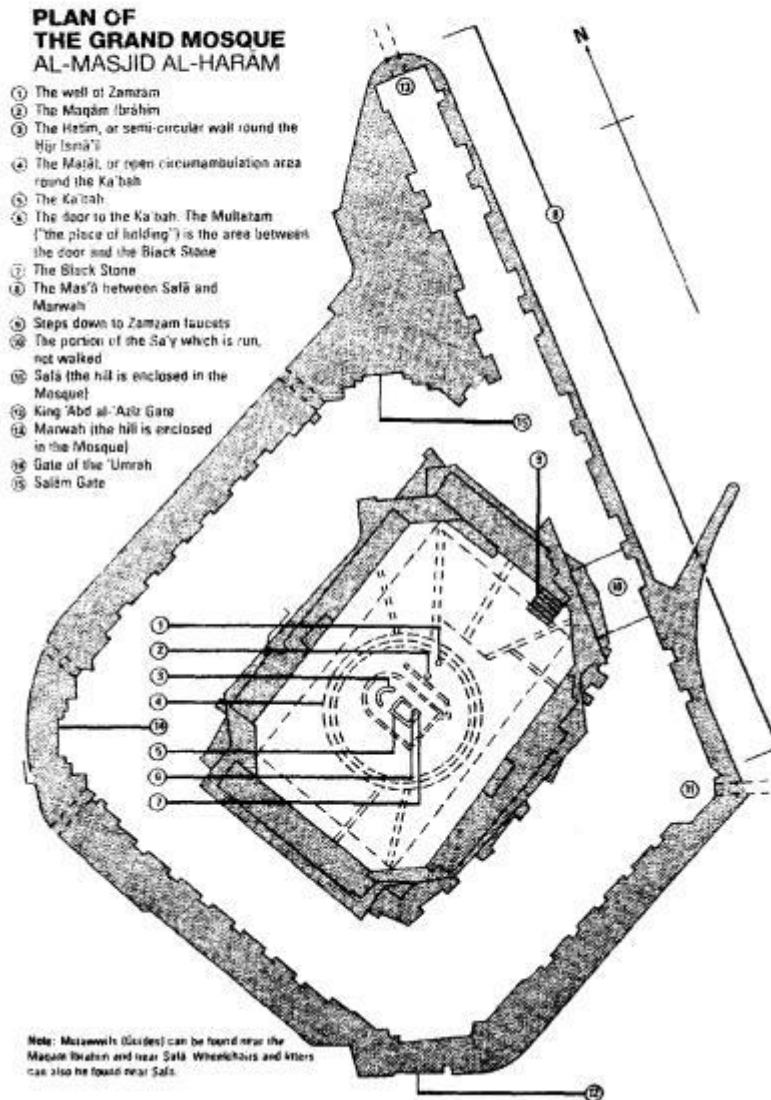

Image:

Sketch of Makkah, Masjid al-Harām and some of the Surrounding Sites



Source URL: <https://www.al-islam.org/secrets-hajj-husayn-mazaheri>

Links

- [1] <https://www.al-islam.org/person/ayatullah-husayn-mazaheri>
- [2] <https://www.al-islam.org/organization/islamic-publishing-house-iph>
- [3] <https://www.al-islam.org/printpdf/book/export/html/116004>
- [4] <https://www.al-islam.org/printepub/book/export/html/116004>
- [5] <https://www.al-islam.org/printmobi/book/export/html/116004>
- [6] <https://www.al-islam.org/person/shaykh-saleem-bhimji>
- [7] <https://www.al-islam.org/tags/hajj>
- [8] <https://www.al-islam.org/tags/soul>
- [9] <https://www.al-islam.org/tags/self-development>

